

Compressed Air Cooling Air AHP(H) Series

BRAZED ALUMINUM CONSTRUCTION

Performance Notes

- Full line of sizes and features
- Brazed bar and plate aluminum core
- Energy efficient
- High performance
- High flows 400-3500 CFM
- Vertical (AHP) or horizontal (AHPH) air flow
- High technology compact design
- Rugged heavy duty construction
- Excellent for heat recovery
- Detachable legs on AHP (shipped unattached)
Fixed mounting Feet on some AHPH models
- CRN Available*



Ratings

Maximum Operating Pressure
250 PSI

Maximum Operating Temperature
350°F

***CRN Rating**
235 psi at 250°F (121°C)

Materials

Cabinet Steel with baked enamel finish

Core Brazed aluminum bar and plate

Fan Aluminum hub, polypropylene blades

Shroud Painted steel

Motor TEFC

Fan Guard Steel with baked enamel finish

How to Order

| | | | | | |
|---------------------|---|--|--|--|--|
| | | | | | |
| Model Series | Model Size Selected | Specify Motor Required | | | |
| AHP | 400 725 950 1200 1600 2000 2500 3000 3500 | 0 - No Motor 2 - Single Phase 60 Hz TEFC 115/208-230 Volt 3 - Three Phase 60 Hz TEFC 230/460 Volt 5 - Air Motor 6 - 575 Volt | | | |

| | | | | | |
|---------------------|---|--|--|--|--|
| | | | | | |
| Model Series | Model Size Selected | Specify Motor Required | | | |
| AHPH | 400 725 950 1200 1600 2000 | 0 - No Motor 2 - Single Phase 60 Hz TEFC 115/208-230 Volt 3 - Three Phase 60 Hz TEFC 230/460 Volt 5 - Air Motor 6 - 575 Volt | | | |

Dimensions

AHP – Vertical Air Flow

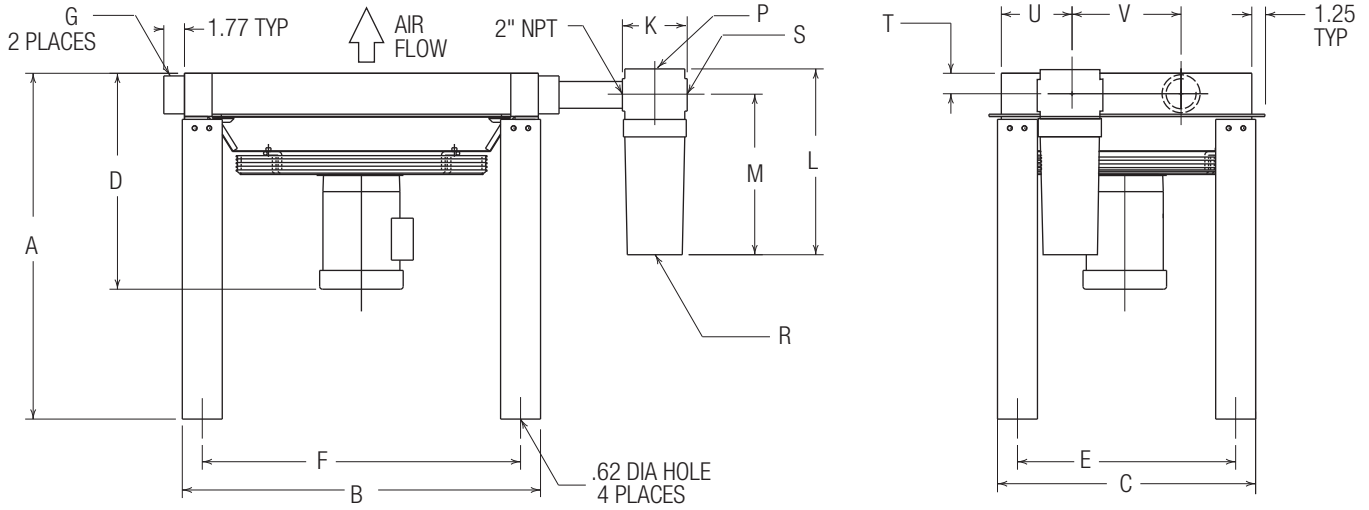

| Model | A | B | C | D Approx. | | E | F | G NPT | Optional Separator | | | | | | T | U | V | Recommended Optional Separator Model Number |
|----------|-------|-------|-------|-------------------|--------------|-------|-------|----------|--------------------|-------|-------|----------|----------|----------|------|------|-------|--|
| | | | | Electric Motor | Air Motor | | | | K | L | M | P NPT | R NPT | S NPT | | | | |
| AHP-400 | 34.20 | 22.6 | 17.96 | 18.01 | 13.55 | 13.96 | 18.68 | 2 | 4.70 | 18.60 | 16.00 | N/A | .50 | 2 | 1.85 | 6.00 | 4.92 | S-600M |
| AHP-725 | 34.20 | 30.56 | 22.37 | 18.01 | 13.55 | 18.37 | 26.56 | 2 | 4.70 | 18.60 | 16.00 | N/A | .50 | 2 | 1.85 | 6.00 | 9.34 | S-600M |
| AHP-950 | 36.01 | 37.24 | 26.78 | 22.76 | 19.01 | 22.78 | 33.24 | 3 | 8.00 | 23.00 | 20.00 | N/A | .50 | 2 | 1.85 | 6.00 | 13.76 | S-1700M |
| AHP-1200 | 36.01 | 41.19 | 26.78 | 25.07 | 20.50 | 22.78 | 37.19 | 3 | 8.00 | 23.00 | 20.00 | N/A | .25 | 3 | 2.76 | 6.00 | 13.76 | S-1700M |
| AHP-1600 | 36.01 | 41.19 | 34.89 | 25.95 | 17.06 | 30.89 | 37.19 | 3 | 8.00 | 23.00 | 20.00 | .50 | .25 | 3 | 2.76 | 8.00 | 17.86 | S-2600M |
| AHP-2000 | 36.01 | 51.04 | 37.88 | 27.57 | 22.23 | 33.88 | 47.04 | 4 | 16.75 | 30.50 | 23.25 | .50 | .25 | 3 | 2.76 | 8.00 | 20.86 | S-2600M |
| AHP-2500 | 36.01 | 49.07 | 43.70 | 28.01 | 22.23 | 39.70 | 45.07 | 4 | 16.75 | 30.50 | 23.25 | .50 | .75 | 4 | 2.76 | 8.00 | 26.68 | S-2600M |
| AHP-3000 | 36.01 | 51.04 | 52.52 | 29.17 | 23.56 | 48.52 | 47.04 | 4 | 16.75 | 30.50 | 23.25 | .50 | .75 | 4 | 2.76 | 8.00 | 35.50 | S-2600M |
| AHP-3500 | 36.01 | 51.04 | 56.30 | 29.17 | 23.56 | 52.30 | 47.04 | 4 | 16.75 | 30.50 | 23.25 | .50 | .75 | 4 | 2.76 | 8.00 | 39.28 | S-2600M |

Note: We reserve the right to make reasonable design changes without notice. All Dimensions are in inches.

Dimensions

AHPH – Horizontal Air Flow

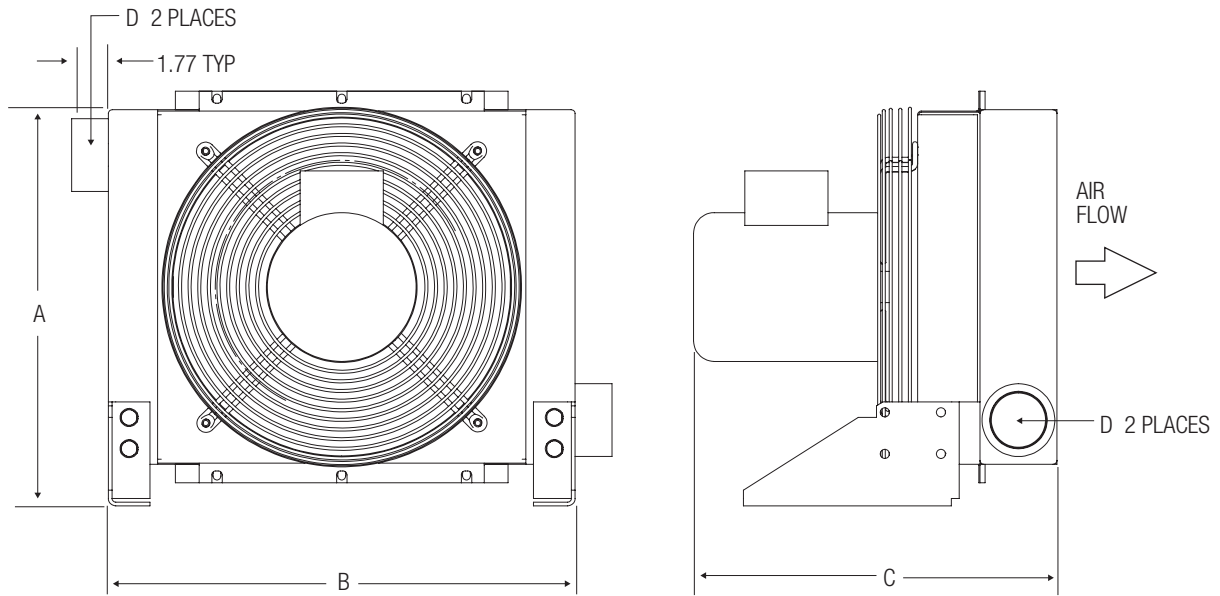

| Model | A | B | C | | D NPT | Recommended Optional Separator Model Number |
|-----------|-------|-------|-------------------|--------------|----------|---|
| | | | Electric Motor | Air Motor | | |
| AHPH-400 | 19.05 | 22.45 | 18.01 | 13.55 | 2" | S-600 M |
| AHPH-725 | 23.46 | 30.31 | 18.01 | 13.55 | 2" | S-600 M |
| AHPH-950 | 27.75 | 37.02 | 22.76 | 19.01 | 3" | S-1700 M |
| AHPH-1200 | 27.87 | 40.94 | 25.07 | 20.50 | 3" | S-1700 M |
| AHPH-1600 | 36.11 | 40.84 | 25.95 | 17.06 | 3" | S-2600 M |
| AHPH-2000 | 38.30 | 51.26 | 27.57 | 22.23 | 4" | S-2600 M |

Note: We reserve the right to make reasonable design changes without notice. All Dimensions are in inches.

Specifications

Capacity Selection Chart Max. SCFM @ 5, 10, 15 and 20°F Approach

| Inlet Temp. °F | 150 | | | | 200 | | | | 250 | | | | 300 | | | | 350 | | | | Recommended Optional Separator Model Number |
|----------------|------|------|------|------|------|------|------|------|------|------|------|------|------|------|------|------|-----|------|------|------|---|
| | 5 | 10 | 15 | 20 | 5 | 10 | 15 | 20 | 5 | 10 | 15 | 20 | 5 | 10 | 15 | 20 | 5 | 10 | 15 | 20 | |
| AHP(H)-400 | 210 | 384 | 520 | 605 | 175 | 375 | 430 | 500 | 160 | 300 | 400 | 464 | 135 | 250 | 340 | 396 | 125 | 235 | 305 | 355 | S-600M |
| AHP (H)-725 | 355 | 650 | 890 | 1025 | 308 | 560 | 760 | 880 | 290 | 545 | 725 | 840 | 245 | 450 | 605 | 701 | 225 | 410 | 540 | 625 | S-600M |
| AHP (H)-950 | 480 | 871 | 1178 | 1360 | 415 | 754 | 1020 | 1180 | 390 | 712 | 950 | 1100 | 320 | 588 | 785 | 910 | 280 | 520 | 690 | 780 | S-1700M |
| AHP (H)-1200 | 600 | 1090 | 1475 | 1710 | 520 | 950 | 1290 | 1460 | 490 | 900 | 1200 | 1380 | 405 | 735 | 980 | 1130 | 355 | 650 | 865 | 990 | S-1700M |
| AHP (H)-1600 | 790 | 1440 | 1950 | 2260 | 710 | 1290 | 1720 | 1950 | 660 | 1200 | 1600 | 1860 | 530 | 965 | 1290 | 1480 | 460 | 840 | 1135 | 1300 | S-1700M |
| AHP (H)-2000 | 980 | 1790 | 2420 | 2800 | 870 | 1580 | 2140 | 2460 | 820 | 1490 | 2000 | 2300 | 660 | 1210 | 1595 | 1840 | 572 | 1040 | 1400 | 1610 | S-2600M |
| AHP-2500 | 1220 | 2220 | 3000 | 3470 | 1090 | 1980 | 2680 | 3100 | 1035 | 1880 | 2500 | 2870 | 784 | 1426 | 1980 | 2270 | 705 | 1290 | 1725 | 1980 | S-2600M |
| AHP-3000 | 1450 | 2650 | 3580 | 4120 | 1295 | 2360 | 3200 | 3710 | 1243 | 2260 | 3000 | 3450 | 985 | 1794 | 2360 | 2715 | 840 | 1530 | 2040 | 2350 | S-2600M |
| AHP-3500 | 1680 | 3064 | 4140 | 4800 | 1530 | 2785 | 3760 | 4320 | 1460 | 2660 | 3500 | 4015 | 1150 | 2090 | 2760 | 3200 | 950 | 1740 | 2350 | 2700 | S-2600M |

Above specifications are based on 80 to 125 PSIG operating pressures. Maximum pressure drop, less than 3 psi. A flexible metal hose must be properly installed between the compressor and aftercooler to validate warranty. In addition, for mobile and other applications where there may be additional stresses to the connections, our 4-bolt SAE Flange should be used. Consult factory for pricing and availability.

Electric Motor & Fan Data

| Model | Fan CFM | Motor HP | Voltage | Phase | Full Load Amps | HZ | RPM | Nema Frame | Thermal Overload | Approximate Shipping Weight (LBS) | Sound dB(A) at 3 FT |
|-------------|-----------|----------|-------------|-------|----------------|-------|-----------|------------|------------------|-----------------------------------|---------------------|
| AHP(H)-400 | 2200 | 1.0 | 115/208-230 | 1 | 6.0 | 60 | 3450 | 56C | No | 120 | 97 |
| | 1825/2200 | 1.0 | 208-230/460 | 3 | 3.6/3.2 | 50/60 | 2850/3450 | 56C | No | 120 | 97 |
| AHP(H)-725 | 3600 | 1.5 | 115/208-230 | 1 | 8.5 | 60 | 3450 | 56C | No | 170 | 100 |
| | 3025/2200 | 1.5 | 208-230/460 | 3 | 4.9-4.6/2.3 | 50/60 | 2850/3450 | 56C | No | 170 | 100 |
| AHP(H)-950 | 4700 | 1.5 | 115/208-230 | 1 | 8.6 | 60* | 1740 | 145TC | No | 330 | 92 |
| | 4700 | 1.5 | 208-230/460 | 3 | 4.6 | 60* | 1740 | 145TC | NO | 330 | 92 |
| AHP(H)-1200 | 7000 | 5.0 | 230 | 1 | 23.0 | 60* | 1740 | 184TC | No | 450 | 94 |
| | 7000 | 3.0 | 208-230/460 | 3 | 8.8 | 60* | 1740 | 182TC | No | 450 | 94 |
| AHP(H)-1600 | 9700 | 5.0 | 208-230/460 | 3 | 13.4 | 60* | 1740 | 184TC | No | 515 | 96 |
| AHP(H)-2000 | 11000 | 7.5 | 230/460 | 3 | 19.6 | 60* | 1740 | 213TC | No | 600 | 98 |
| AHP-2500 | 14000 | 7.5 | 230/460 | 3 | 19.6 | 60* | 1740 | 213TC | No | 625 | 98 |
| AHP-3000 | 17500 | 10.0 | 230/460 | 3 | 24.8 | 60* | 1740 | 215TC | No | 645 | 102 |
| AHP-3500 | 17500 | 10.0 | 230/460 | 3 | 24.8 | 60* | 1740 | 215TC | No | 750 | 102 |

All motors shown are TEFC. Other motor options available upon request. Published electrical ratings are approximate, and may vary because of motor brand. Actual ratings are on motor nameplate. Fan motors **must not** be cycled. Outdoor applications must be protected from direct weather. If ductwork or additional static resistance is added to the cooler airstream, an auxiliary air mover may be required. *3 phase motors available in 50Hz. Reduce performance by 10%.

Recommended Typical Installation

- Support piping as needed. Flexible connectors must be properly installed to validate warranty.
- Coolers should not operate in ambient temperatures below 35°F (1°C). Consult factory for recommendations.
- The fan cannot be cycled.
- AHP coolers operated outdoors must be protected from weather. Consult factory for recommendations.
- If ductwork or additional static resistance is added to the cooler airstream, an auxiliary air mover may be required.

Air Motor Data

| Model | PSI ¹ | CFM ² | Approximate Shipping Weight of Cooler with Air Motor (LBS) |
|-------------|------------------|------------------|--|
| AHP(H)-400 | 60 | 50 | 105 |
| AHP(H)-725 | 85 | 65 | 140 |
| AHP(H)-950 | 60 | 55 | 425 |
| AHP(H)-1200 | 70 | 100 | 481 |
| AHP(H)-1600 | 100 | 180 | 595 |
| AHP(H)-2000 | 90 | 230 | 700 |
| AHP-2500 | 90 | 230 | 735 |
| AHP-3000 | 100 | 275 | 795 |
| AHP-3500 | 100 | 275 | 825 |

Note: We reserve the right to make reasonable design changes without notice.

¹ Air inlet to the air motor must be regulated to this pressure.

² CFM (Free Air) consumption of the air motor. Lubrication = One drop of oil for every 50-75 CFM of air going through the motor. Use detergent SAE #10 oil. Filter, regulator and lubricators for the air motors are required, but not included.

General Information

1. Air cooled aftercoolers are built for operation with maximum air pressure of 250 PSI (17.2 BAR) and temperature of 350°F (176°C).
2. The motors furnished are built for fan duty. Consideration should be given to the installation location so motors **are not subjected to extreme temperatures**.
3. AHP Coolers are **not** to be operated in ambient temperatures below 35°F (1°C).
4. The fan **cannot** be cycled.
5. AHP coolers operated outdoors **must be protected** from weather. Consult factory for recommendations.

Installation

1. Aftercoolers should not be located in corrosive atmospheres as rapid deterioration of fan shroud, cooling coil, fan and motor may take place resulting in reduced life.
2. Piping should be sized based on air flow and pressure drop requirements, and not on the aftercooler's supply and return connection size.
3. A strainer located ahead of the aftercooler should be installed to trap scale, dirt or sludge that may be present in piping and equipment, or that may accumulate with use.
4. A separator/trap/drain should be installed in the outlet piping of the aftercooler to remove condensate.
5. Flexible connectors should be installed to prevent the stressing of manifolds. (Must be properly installed to validate warranty.)
6. Arrange the outlet pipe so that the moisture that condenses within the aftercooler can drain freely by gravity.
7. For proper air flow, a minimum of 12" clearance should be allowed between the aftercooler fan and any wall or obstructions.

Electrical

1. **CAUTION To prevent possible electrical shock, it is important to make sure this unit is grounded properly.**
2. Connect motor only to a power supply of the same characteristics as shown on the motor nameplate. Be sure to provide proper fusing to prevent possible motor burnout. Before starting motor, follow manufacturer's recommendations. Turn fan manually to eliminate possible motor burn out in the event the fan has been damaged in shipment. Observe operation after motor is started for the first time.

Maintenance

Inspect the unit regularly for loose bolts and connections, rust and corrosion, and dirty or clogged heat transfer surfaces (cooling coil).

Heat Transfer Surface

Dirt and dust should be removed by brushing the fins and tubes and blowing loose dirt off with an air hose. Should the surface be greasy, the motor should be removed and the fins and tubes brushed or sprayed with a non-flammable degreasing fluid. Follow with a hot water rinse and dry thoroughly. A steam hose may also be used effectively. Do not clean with caustic cleaners

Fan Shroud, Fan and Motor:

Dirt and grease should be removed from these parts. Rusty or corroded surfaces should be sanded clean and repainted.

Internal Cleaning

Once a year piping should be disconnected and a degreasing agent or flushing oil circulated through the unit to remove sludge from turbulators and internal tube surfaces to return the unit to full capacity. A thorough cleaning of the entire system in the same manner is preferable to avoid carry-over from uncleaned piping, pump and accessories. The strainer of any filtering devices should be removed and serviced following this cleaning operation.

Motor

Keep outside surface free of dirt and grease so motor will cool properly. Ball bearing equipped motors are sealed, and do not require greasing. Motors with Alemite fittings require lubrication every 6 months. Clean tip of fitting and apply grease gun. Use 1 to 2 full strokes on motors in NEMA 215 frame and smaller. Use 2 to 3 strokes on NEMA 254 through NEMA 365 frame. Use 3 to 4 strokes in NEMA 404 frame or larger.

CAUTION Keep grease clean. Lubricate motors at standstill. Do not mix petroleum grease and silicone grease in motor bearings.

Repair or Replacement of Parts

When ordering replacement parts or making inquiry regarding service, mention model number, serial number and the original purchase order number. Any reference to the motor must carry full nameplate data.

AHP(H) / AOL / ACOC(H) Series

0916

1. The cooler storage area should be dry and maintained at a constant room temperature.
2. In order to minimize and/or eliminate condensation (on both the inside and outside surfaces of the cooler), coolers **should not be moved** from warm areas to cold areas without prior adjustment of the room temperature in order to minimize the temperature changes which result in condensation. If this criteria cannot be met, the cooler shall be sealed in plastic bags with desiccant added.
3. For coolers which will be stored up to a maximum of 6 months: No specific internal corrosion protection procedures are required. All cooler openings shall be sealed with plastic plugs.
4. For coolers which will be stored from 6 months to 24 months: These coolers should be internally flushed with oil and all cooler openings sealed with plastic plugs.
5. For coolers which will be stored for more than 24 months: These coolers should be completely filled with oil and sealed. These coolers should then be flushed, inspected, refilled with oil, and sealed every 24 months.
6. For compressor aftercoolers after installation:
 - 6.1 Any condensation should be thoroughly removed from the aftercooler after the initial trial run of the compressor.
 - 6.2 In the event a compressor is to be stored, or not used for a period of 6 months to 24 months, the aftercooler should be internally flushed with oil, and all cooler openings sealed.
 - 6.3 In the event a compressor is to be stored, or not used for a period of more than 24 months, the aftercooler **should be completely filled** with oil and sealed. the aftercooler should then be flushed, inspected, refilled with oil, and sealed every 24 months.
 - 6.4 Prior to compressor start-up, any corrosion protection oil **should be removed** from the aftercooler.