

AEL AKG ENGINE LINE

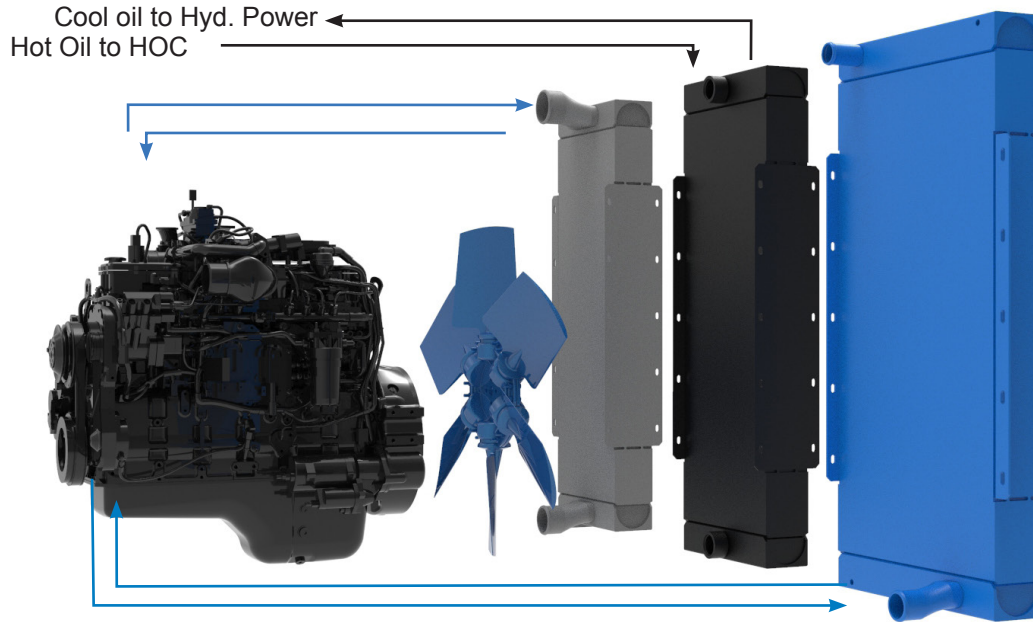

Ambient
 Temperature:
 Elevation:
 Fan Speed:

CHARGE AIR COOLER:

Inputs:	
Charge Air Flow:	-
Turbo Outlet Temperature:	-
Turbo Outlet Pressure:	-
Specifications:	
CAC Outlet Temp/IMTD	-

OIL COOLER:

Inputs:	
Oil Flow:	-
Jacket Water Heat Rejection:	-
Operating Pressure:	-
Specifications:	
Max. Coolant Temperature:	-
Max. Pressure Drop:	-

RADIATOR:

Specifications:	
Max. Coolant Temperature:	-
Max. Pressure Drop:	-
Inputs:	
Coolant Flow:	-
Jacket Water Heat Rejection:	-

ORDERING INFORMATION

Size	Approx. HP Rating	
AEL01	30-100hp	Radiator and Charge Air Cooler
AEL02	100-200hp	
AEL03	200-300hp	
AEL04	300-400hp	
AEL05	400-500hp	
AEL06	500-600hp	
AEL07	600-700hp	
AEL11	30-100hp	Includes Optional Oil Cooler
AEL12	100-200hp	
AEL13	200-300hp	
AEL14	300-400hp	
AEL15	400-500hp	
AEL16	500-600hp	
AEL17	600-700hp	

Fan Drive:	
H	Hydraulic Motor
N	Hydraulic Motor Mount Only
E	Engine Drive (Choose for 'No Fan')

Fan Direction:	
B	Blower Fan
S	Sucker Fan
X	No Fan

Fan:	
L	Low Static
H	Standard
X	No Fan

Core Guard:	
G	Guard Included
X	None

Mounting Base:	
B	Base Included
X	None

Surge Tank:	
T	Surge Tank Included
X	None

Thermal Transfer Systems Inc
 PH: 800-527-0131
 FAX: 972-242-7568
 Email: Sales@ThermalTransfersystems.com

AEL AKG ENGINE LINE

DIMENSIONS

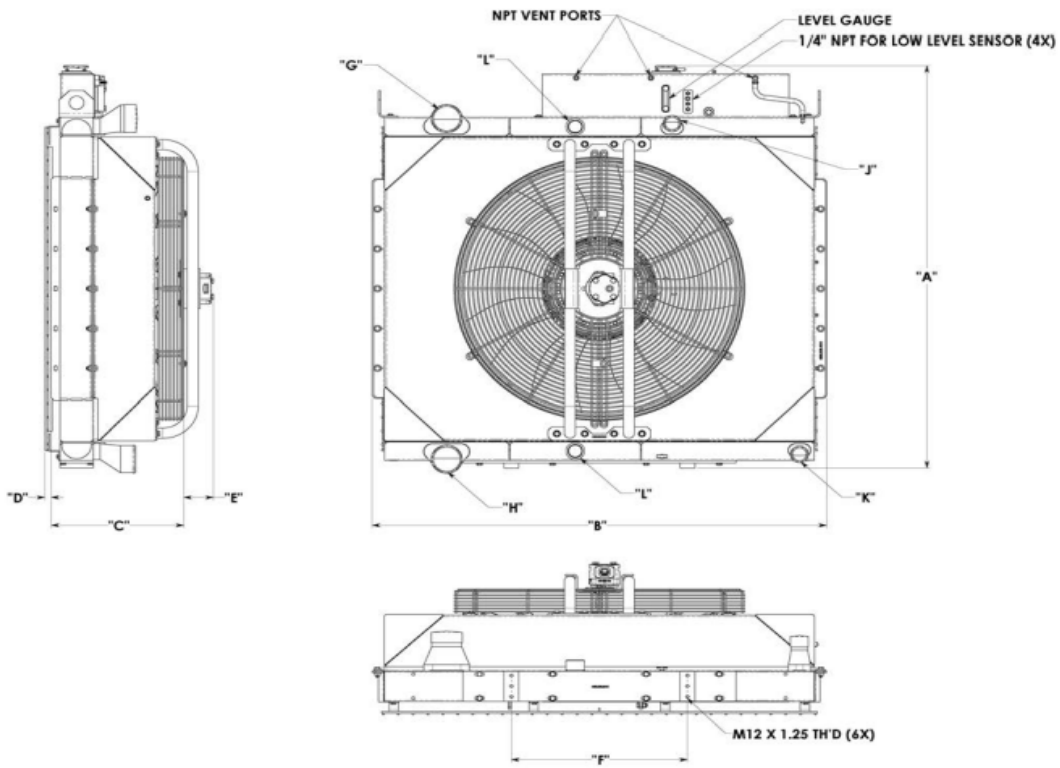

Model Size	A	B	C	D	E	F	G	H	J	K	L
01	40.1	25.7	14.1	2.0	4.0	13.4	3	2.5	1.5	2	-
02	44.5	28.5	13.9	2.0	4.0	16.5	3	3	1.75	2.25	-
03	49.3	32.9	14.5	2.0	4.0	19.7	3.5	3	1.75	2.25	-
04	53.3	38	15.0	2.0	4.6	23.6	3.5	3	1.75	2.25	-
05	59.8	43.3	15.0	2.0	5.4	23.6	4	4	2.25	2.25	-
06	57.6	45.8	16.1	2.0	5.4	27.6	4	4	2.5	2.5	-
07	63.6	56.8	21.8	2.0	7.4	39.4	4	4	2.5	2.5	-
11	40.1	39.3	14.1	2.0	4.0	13.4	3	2.5	1.5	2	1
12	44.5	40.9	13.9	2.0	4.0	16.5	3	3	1.75	2.25	1
13	49.3	44.1	14.5	2.0	4.0	19.7	3.5	3	1.75	2.25	1
14	53.3	53.2	15.0	2.0	4.6	23.6	3.5	3	1.75	2.25	1.5
15	59.8	61	15.0	2.0	5.4	23.6	4	4	2.25	2.25	1.5
16	57.6	60.5	16.1	2.0	5.4	27.6	4	4	2.5	2.5	1.5
17	63.6	84.3	21.8	2.0	7.4	39.4	4	4	2.5	2.5	1.5